

# UNO/DOS LINEAR

## Standard Mount Installation ou de montage

**WARNING:** Disconnect main power at the source prior to installation! Fixture must be installed by a qualified electrician.

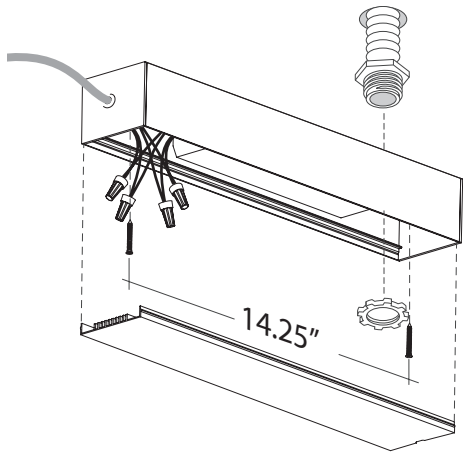

Mount drive housing to surface with screws.  
Use clear O-rings to tether cord along cable  
for support and more tidy appearance.

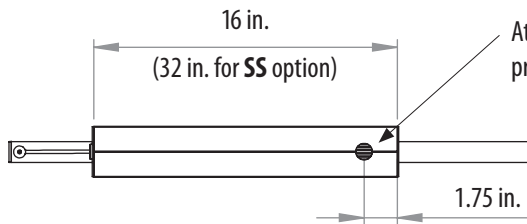
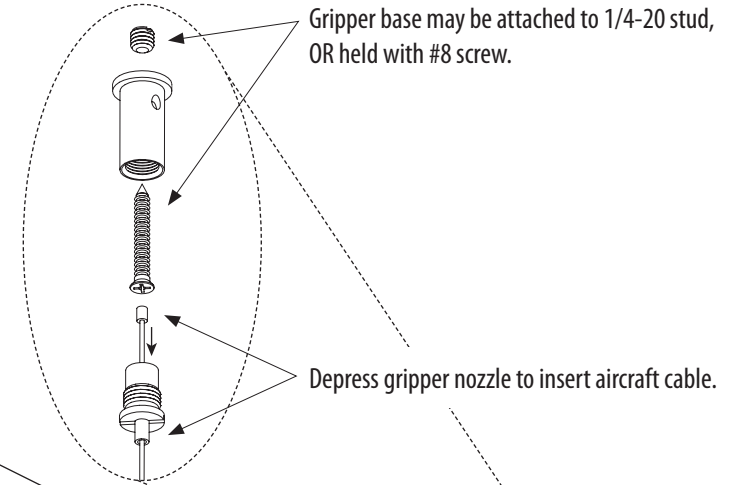
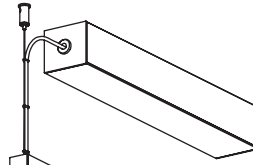

Attach conduit to top of driver housing for  
primary power.

